

## auto electrical parts

### Technical Information Sheet

#### Part No. 0-443-37

LED Beacon Light Bar, Amber, 12/24v,  
Magnetic Mount (Speed Rated 70MPH), 10  
Flash Patterns, 72 x 0.5W LED's, 36W Max  
Power. IP67. 0.5M Flying Leads, E Marked R10  
EMC.



#### Technical Drawing (not to scale)

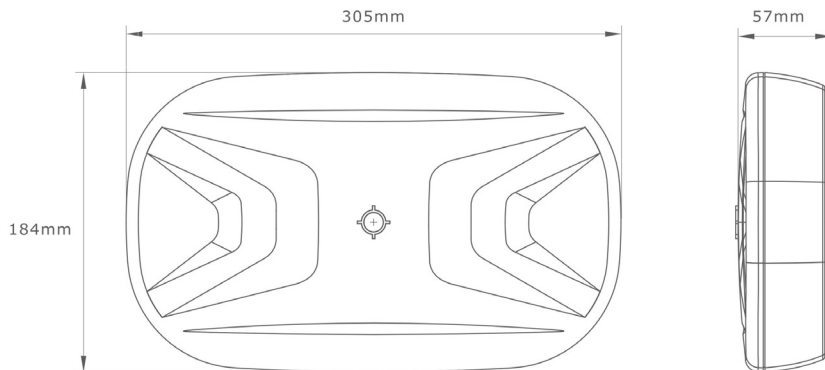

#### Specification

Type	LED Light Bar
Colour	Amber
Voltage	12/24V
Current	3A @ 12VDC
Number of LED's	72
LED Power	0.5W
Lens	Polycarbonate
Housing	ABS
Weight	1.5Kg
Dimensions	305*184*57mm
IP Rating	IP67
Flash Patterns	10
Compliance	E Marked ECE R10 EMC

The information contained in this document is correct to the best of our knowledge at the time of printing. However, specifications may change at any time without notice.